

ORDTECH AMMUNITION

14.5 X 51 mm
Sub-Calibre Ammunition
for Artillery Training

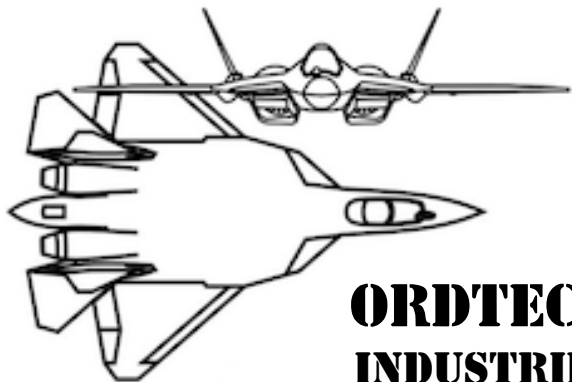
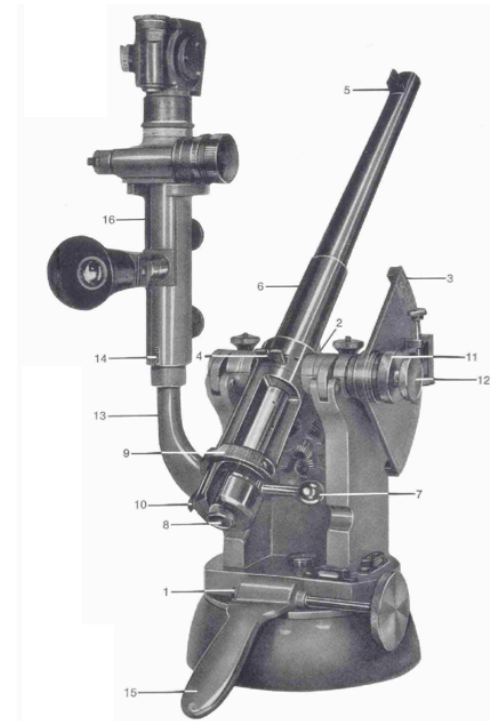

**ORDTECH
INDUSTRIES**

Ref.1305 BROCHURE

ORDTECH AMMUNITION

14.5 X 51 mm Sub-Calibre for Artillery Training

GENERAL CHARACTERISTICS

Designation	14.5 mm ATA
Fuze Type	Nose Point Detonating
Cartridge Case Material	Steel
Cartridge Length	65 mm
Cartridge Mass	12.8 g
Projectile Mass	59 g
Propellant Charge 1	0.25 g
Propellant Charge 2	0.28 g
Propellant Charge 3	0.33 g



ORDTECH AMMUNITION

14.5 X 51 mm Sub-Calibre
for Artillery Training

PRINCIPAL COMPONENTS Part 1

1	PROJECTILE
2	CARTRIDGE CASE
3	LEAD JACKET
4	STEEL CASE INTERMEDIATE
5	PROPELLANT COMPOSITION
6	PRIMING CAP WITH PRIMER
7	FIRING PIN
8	SAFETY PIN

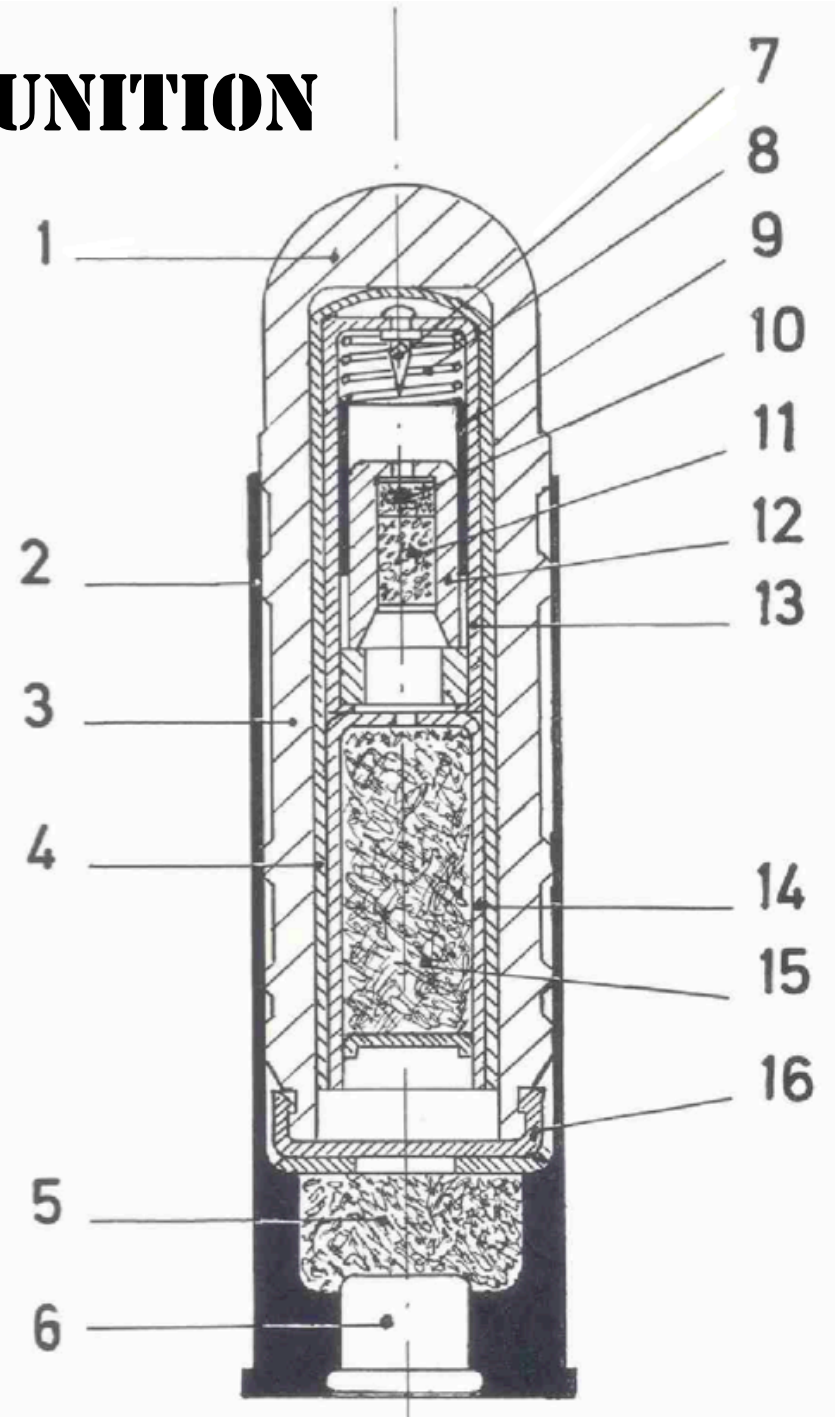

ORDTECH AMMUNITION

14.5 X 51 mm Sub-Calibre
for Artillery Training

PRINCIPAL COMPONENTS Part 2

9	SAFETY CASING
10	IGNITER
11	BOOSTER
12	FIRING BOLT
13	IGNITER CASE
14	SMOKE COMPOSITION CASE
15	SMOKE COMPOSITION
16	PLASTIC BASE CAP

ORDTECH
INDUSTRIES

Ref.1305 BROCHURE

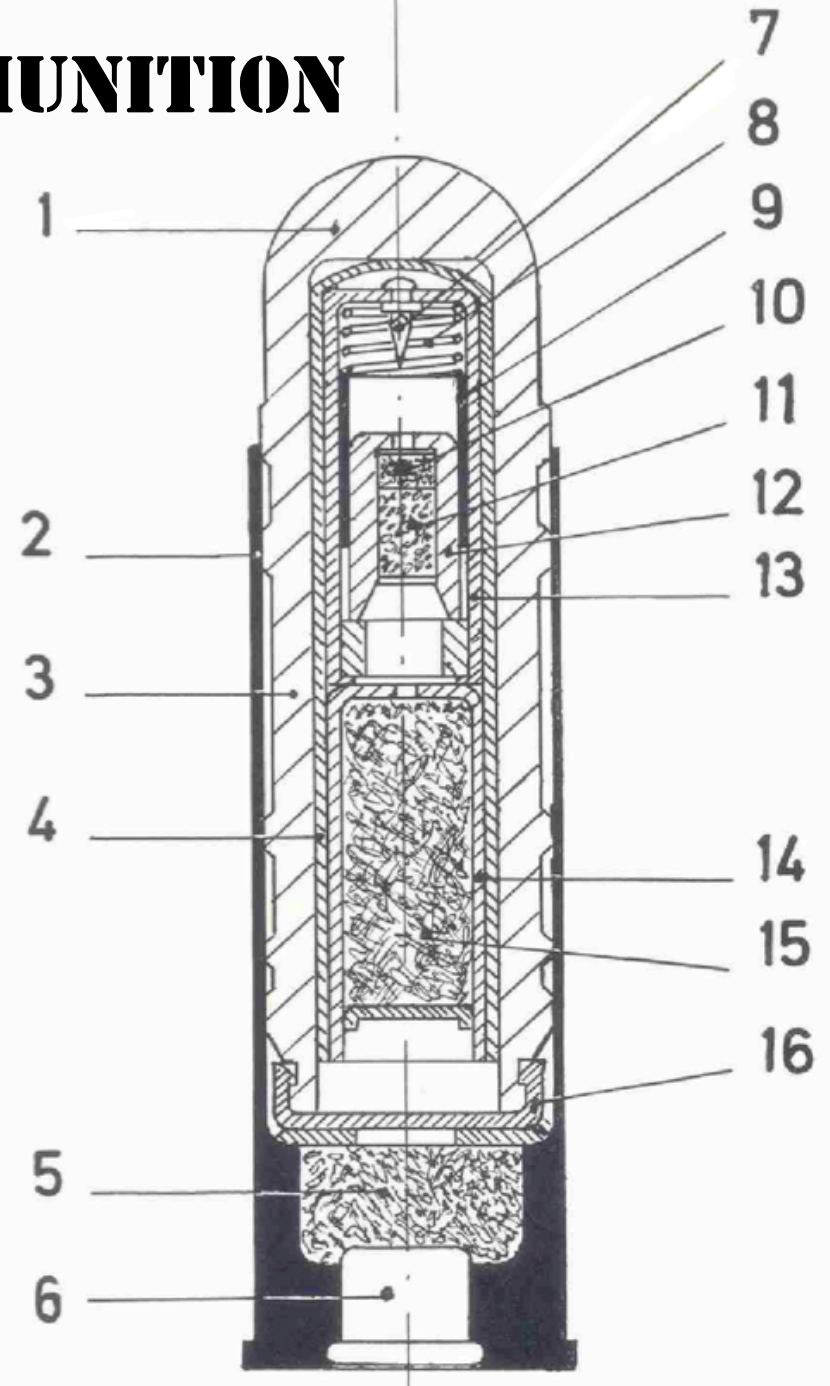

ORDTECH AMMUNITION

14.5 X 51 mm Sub-Calibre for Artillery Training

PERFORMANCE CHARACTERISTICS

Muzzle Velocity – Charge 1	115 ± 4 m/s
Range – Charge 1	894 m
Muzzle Velocity – Charge 2	125 ± 4 m/s
Range – Charge 2	994 m
Muzzle Velocity – Charge 2	135 ± 4 m/s
Range – Charge 3	1146 m
Chamber Pressure	130 MPa / 1300 Bar



ENQUIRIES: REF. #1305

ORDTECH INDUSTRIES
OLYMPIC DIVISION
SMALL CALIBRE AMMUNITION

ORDTECH4 @ GMX.CH
WWW.ORDTECH-INDUSTRIES.COM

Ref.1305 BROCHURE

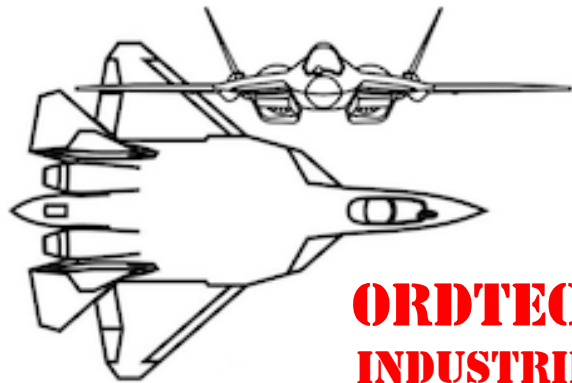

FUZING SYSTEMS
AIRCRAFT ORDNANCE
AIR WEAPONS TECHNOLOGY
AMMUNITION
SMALL
MEDIUM
LARGE CALIBRES